

Silverback Industries, LLC  
 407 E. ALEXANDER AVE  
 TACOMA, WA, 98421  
 www.SilverBackMarine.com



**SILVERBACK**  
 MARINE

**Estimate**

2/9/2024

Elk Rapids  
 Mike Singleton

QTY.	VESSEL SPECIFICATIONS	RATE	TOTAL
1	10X26 WORK BARGE W/ PUSH KNEES	\$ 348,387.03	\$ 348,387.03
<b>PERMANENT HULL ACCESSORY FEATURES</b>			
6	MAIN DECK TIE DOWNS, FLUSH		
4	Pad eyes/Lifting Points		
2	4X6 ANODE DIVERS DREAM W/ MOUNT		
6	10" WELDED CLEATS W; 2 AFT, 2 MIDSHIP, 2 FWD.		
1	HDPE SIDE FENDERING		
1	CRANE MOUNT: ½" DOUBLER PLATE W/ SUBDECK STRUCTURE TO KEEL		
1	Sealed Below Deck Access		
2	Spud Wells		
2	Spud Poles		
<b>CONSOLE / WHEELHOUSE FEATURES</b>			
1	Quarter Cabin		
1	Protection for Captain +1		
1	SEA DOG WINDSHIELD WIPER		
<b>PLUMBING, FUEL, HYDRAULIC SYSTEMS</b>			
2	AUTOMATIC 1500 GPH BILGE PUMPS		
2	SHURFLO SEAWATER WASHDOWN PUMPS, 1X PORT, 1X STBD.		
1	SEASTAR HYDRAULIC STEERING SYSTEM		
<b>ELECTRICAL, LIGHTING, &amp; NAVIGATION SYSTEMS</b>			
1	DEPTHFINDER		
1	100 GALLON ALUMINUM FUEL TANK, FUEL / WATER SEPARATORS		
1	12V ELECTRICAL SYSTEM: ANCOR TINNED WIRING THROUGHOUT VESSEL, 6 POSITION BLUE SEA SWITCH PANNEL, FUSES, BATTERY SHUTOFF W/ AUTO CHARGE RELAY, 12V USB PORT AT HELM		
1	FORWARD FACING LED BAR LIGHT, CONSOLE MOUNT		



1	NAVIGATION LIGHTS: 2X LED, CONSOLE MOUNT		
<b>PAINT &amp; FINISHES</b>			
1	COMPANY LOGO PLACED ON CONSOLE		
<b>SAFETY &amp; HANDLING EQUIPMENT</b>			
1	MAXILIFT HYDRAULIC CRANE For marine Workboat Use (Lifting Spuds & Tending Bouys)		
<b>ENGINES &amp; PROPULSION</b>			
2	MERCURY or HONDA 115 H.P. OUTBOARD MOTORS W. PROPS, CONTROLS, INSTALL, OIL & TEST	17,664.29	35,328.58
<b>SHIPPING &amp; MISC.</b>			
1	Saltwater Grade Trailer	15,556.22	15,556.22
1	SHIPPING	13,035.72	13,035.72

SUBTOTAL	412,307.55
WA Sales Tax Pierce County, 10.3%	-
TOTAL	412,307.55

Contact Angela Hermann <angela@silverbackmarine.com> for all our financing options.

**Terms & Conditions of Sale: 40% deposit, 30% upon Substantial Hull Completion, 30% on delivery.** Fabrication of products, skiffs, workboats, or barges are built specifically for the quoted Client, and are considered projects of a custom nature. Returns or refunds are not eligible for custom build projects. Placeholder deposits and progress payments are non-refundable in the event of contract cancellation from the client. Significant variances or changes to the hull shape, structure, accessories, or features after final drawings completion will be subject to a Change Order. Change Orders are billed Time & Materials per hourly rate of \$185.00/hr. Upon completion, Client must inspect and approve the vessel according to the Vessel Acceptance & Factory Release form (VAFR) and complete the Limited 2 Year Warranty & Indemnification document. Final payment is due prior to release of vessel from factory. Delivery schedules are estimates only, and may be affected by supply chain issues, motor availability, economic conditions, and other external influencers. Unless specifically noted, quotation does not include delivery or transport services. Should economic disruption, inflation, pandemic, or supply chain issues impact build progress or commercial feasibility, Silverback Marine reserves the right to refund & nullify contract. Materials pricing fluctuations influenced by supply chain or economic conditions may be reflected at time of progress payment if significant changes to market rates, supply availability, or other pricing influencers take effect for aluminum materials, electrical & electronics components, and outboard motors. Due to the volatility of the supply chain, transportation, extended lead times, etc., we reserve the right to revise our pricing in direct correlation to price surcharges/increases received from our vendors.

Silverback Industries Representative: \_\_\_\_\_

Client Signature: \_\_\_\_\_ Print Name: \_\_\_\_\_ Date: \_\_\_\_\_

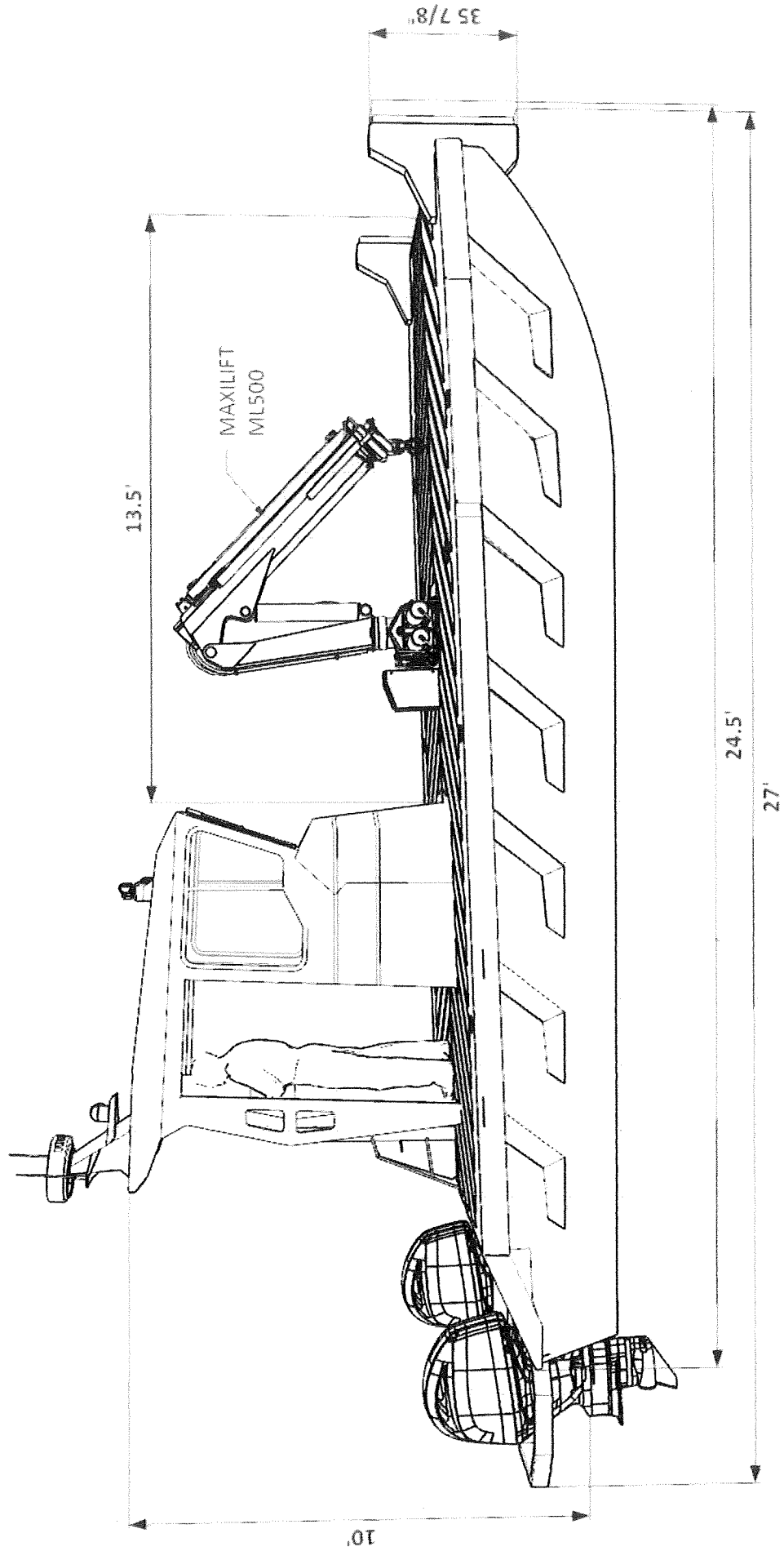

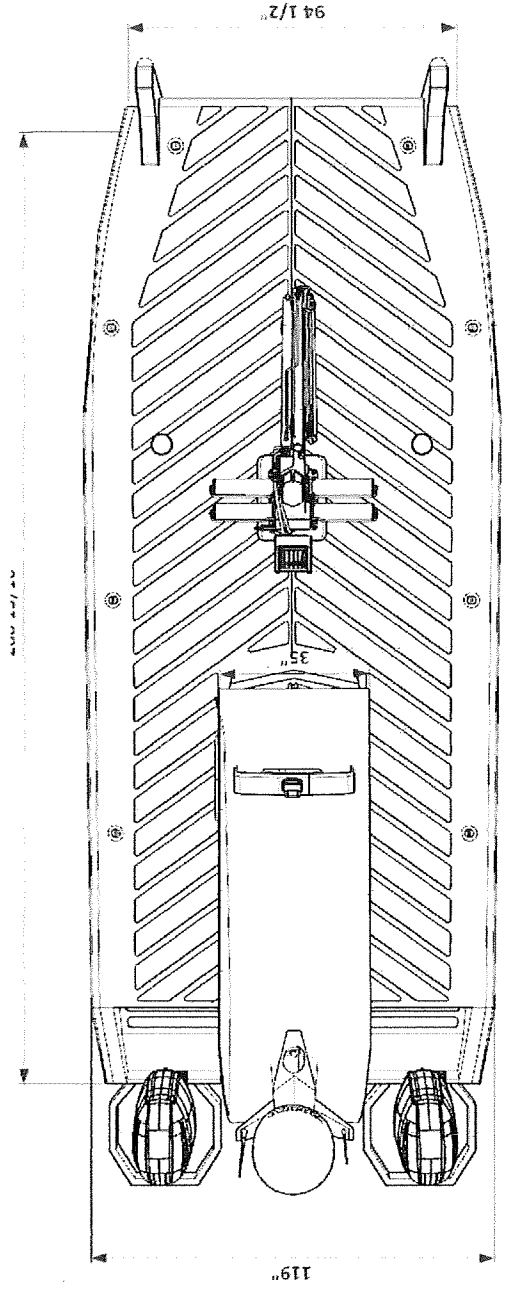
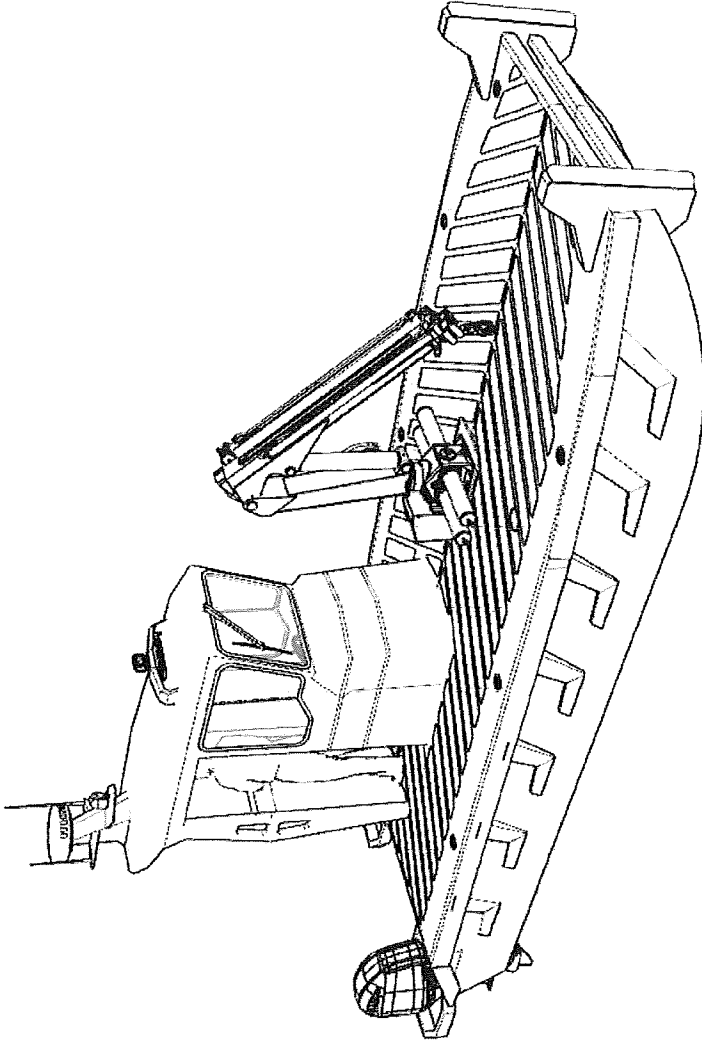
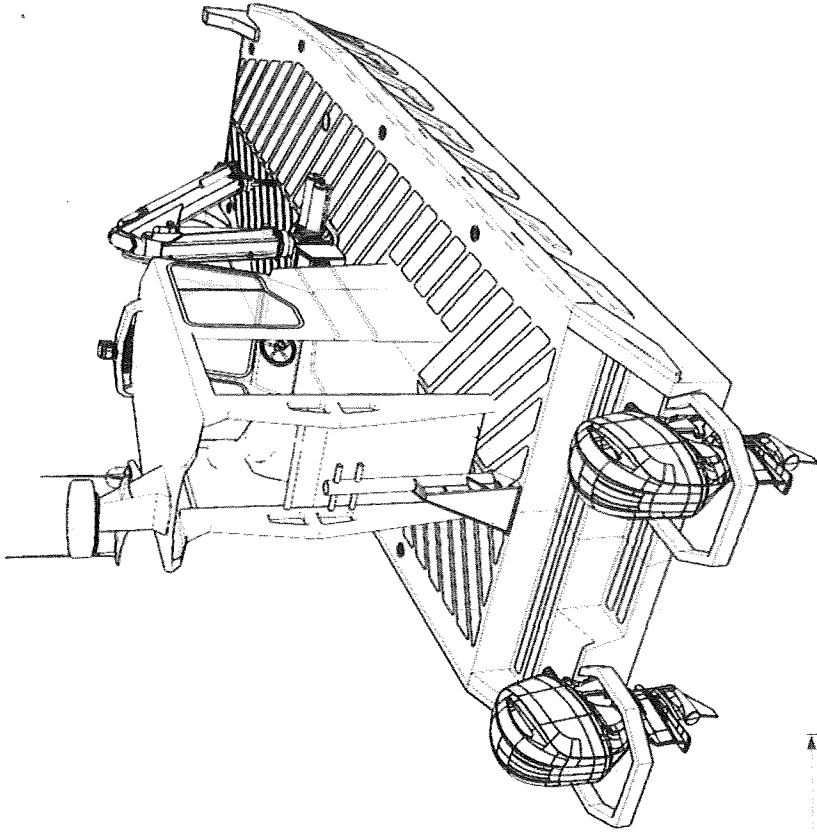



UNITED STATES  
POSTAL SERVICE

Retail

US POSTAGE PAID

\$14.00

Origin: 98023  
02/09/24  
5404920181-02

PRIORITY MAIL  
FLAT RATE ENVELOPE  
POSTAGE REQUIRED

PRIORITY MAIL®

0 Lb 3.70 Oz  
RDC 03

DELIVERED DAY: 02/12/24

R777

315 BRIDGE ST  
ELK RAPIDS MI 49629-5101

USPS SIGNATURE® TRACKING #

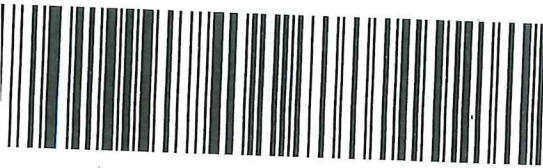

9510 8156 3236 4040 1949 13



USPS.COM/PICKUP



2023  
1/2

NARD C. GRACE MEMORIAL HARBOR

FOR FABRICATION OF WORK BARGE

RECEIVED  
FEB 14 2024  
@ 10:30 AM

FROM:

SILVERBACK MARINE  
407 E ALEXANDER AVE,  
TACOMA, WA 98421  
KYLE GRACEY  
360 - 306 - 9506

TO:

VILLAGE OF ELK RAPIDS  
GOVERNMENTAL CENTER  
315 BRIDGE STREET,  
ELK RAPIDS, MI, 49629  
ATTN: HARBOR MASTER  
MIKE SINGLETON

This packaging is the property of the U.S. Postal Service® and is provided solely for use in sending Priority Mail® and Priority Mail International® shipments. Misuses may be a violation of federal law. This package is not for resale. EP14F © U.S. Postal Service; October 2023; All rights reserved.





*Village of Elk Rapids*

# EDWARD C. GRACE MEMORIAL HARBOR

## Invitation to Bid

Edward C. Grace Memorial Harbor  
**Fabrication of work barge  
with hydraulic crane and trailer**

129 N. Cedar St.  
Elk Rapids, MI 49629

**BIDS DUE:** Friday March 1, 2024  
10:00 a.m., EST

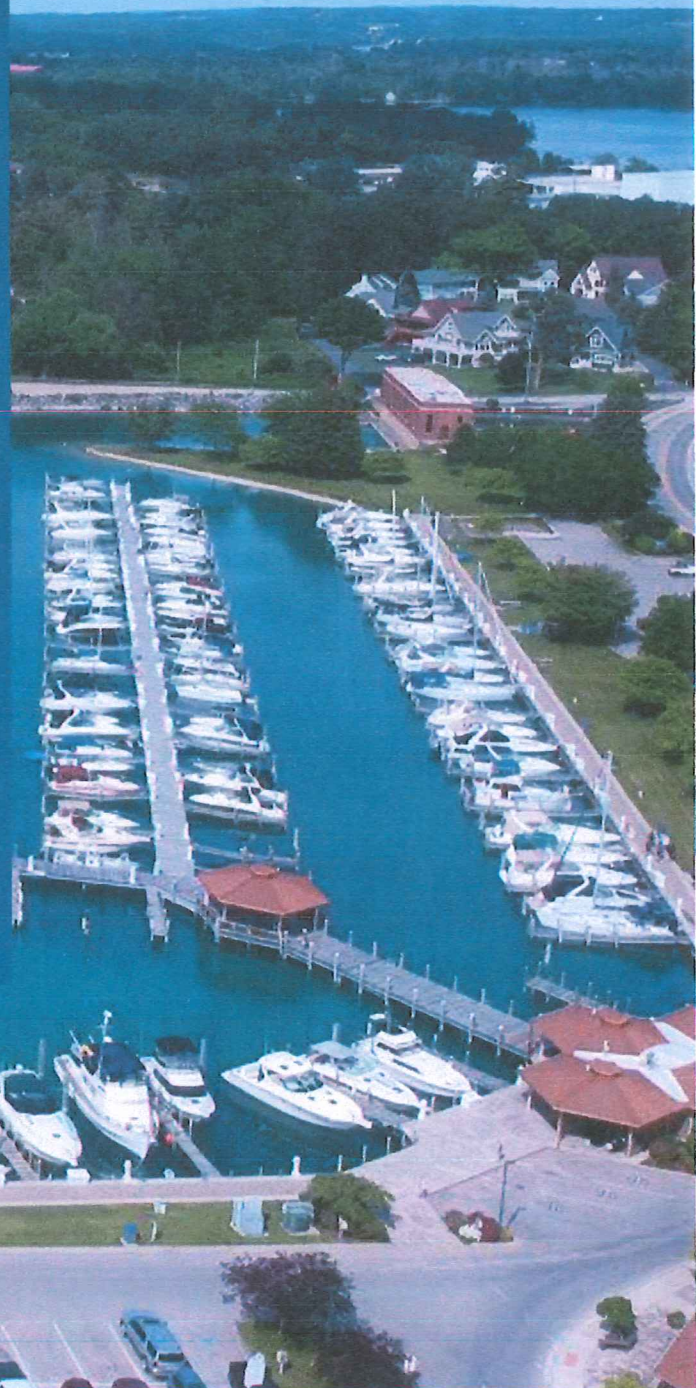



**THIS PAGE WAS INTENTIONALLY LEFT BLANK**

## TABLE OF CONTENTS

<b>SECTION 1 – INVITATION TO PARTICIPATE .....</b>	<b>4</b>
1.1 Purpose .....	4
1.2 RFP Coordinator; Issuing Officer. ....	4
1.3 Presentation and Clarification of the Village’s Intentions .....	5
1.4 Timeline.....	5
<b>SECTION 2 – BACKGROUND AND SCOPE OF WORK .....</b>	<b>6</b>
2.1 Background.....	6
2.2 Proposal Information.....	7
2.3 Requirements .....	7
<b>SECTION 3 – PROPOSAL REQUIREMENTS &amp; GENERAL INFORMATION FOR RESPONDENTS.....</b>	<b>8</b>
3.1 Submission of Respondent’s Proposal .....	8
3.2 Examination and Procurement of Documents .....	9
3.3 MODIFICATION OR WITHDRAWAL OF BID .....	9
3.4 Pre-Bid.....	9



## SECTION 1 – INVITATION TO PARTICIPATE

### 1.1 Purpose

Notice is hereby given that the Village of Elk Rapids ("the Village") soliciting a Request For Proposal (RFP) for the following: Fabricate a functional work barge that will be capable of setting navigational markers with a hydraulic crane, raising and lowering fixed docks, and placing swim zone buoys/no wake buoys in shallow waters that are considered boating restricted areas. The barge will need to be sufficiently powered with an outboard engine, have a spud system to hold its position while conducting work, and it will include all navigational safety features required by local, state and federal laws as required. The barge will need a trailer in order to be transported to the inland lake side of the harbor's large facility.

Respondents must offer a proposal that will meet the scope of services, requests and general description of work activities identified in this RFP, while adding what the Respondent would have to offer.

### 1.2 RFP Coordinator; Issuing Officer

This RFP is issued for the Village. The RFP Coordinator, identified below, is the point of contact from the date of distribution until the selection of the successful Respondent.

**Mike Singleton**  
Harbormaster  
Village of Elk Rapids  
315 Bridge Street  
PO Box 398  
Elk Rapids, MI 49629  
[Harbormaster@elkrapids.org](mailto:Harbormaster@elkrapids.org)





Figure 1: Aerial view of the Edward C. Grace Lower Harbor.

### 1.3

#### Presentation and Clarification of the Village's Intentions

As a result of this RFP, the Village intends to enter into a contract with the selected Respondent to supply the services described in this RFP. However, this intent does not commit the Village to award a contract to any Respondent, nor to pay any costs incurred in the preparation of the proposal, nor to procure or contract for any services. The Village reserves the right, in its sole discretion, to accept or reject, in part or in its entirety, any proposal received. At its discretion, the Village may award one or more contracts to one or more qualified Respondents to achieve the objectives of this RFP if it is in the best interest of the Village.

### 1.4 Timeline

The schedule of events for this RFP is anticipated to proceed as follows:

- This RFP will be distributed on February 6, 2024.
- **Final RFP submissions must be received no later than Friday, March 1, 2024, at 10:00 a.m., Eastern Standard Time.**
- Respondents will be notified by the RFP Coordinator if the Village will be accepting the bid or not.
- Work to begin on or about April 1<sup>st</sup>, 2024.
- Delivered no later than November 1<sup>st</sup>, 2024.



## SECTION 2 – BACKGROUND AND SCOPE OF WORK

### 2.1 Background

The Village of Elk Rapids is a General Law Village and a rural community located in the southwest corner of Antrim County, Michigan. According to the 2020 census, the population of the Village of Elk Rapids at that time was 1,529.

The Village of Elk Rapids is a quaint community founded in 1855, with a traditional main street and a scenic river flowing alongside its central business corridor. The Village was established amidst agricultural fields, prominent water features and open land, much of which has retained its original character.

The Edward C. Grace Memorial Harbor was constructed in the 1950s by a group of dedicated volunteers. Completion of the initial harbor project was officially recognized by the then Michigan Governor George Romney during the Village's Harbor Days festival in 1961. Harbor operations have continually expanded over the years to the current capacity of 265 slips.

The Harbormaster is appointed by the Village Manager to supervise daily operations of all Village harbors and boating facilities. There are three full-time staff members who supervise approximately twenty seasonal support staff.

The Harbor Commission consists of seven members, serving staggered 4-year terms, who are appointed with the majority consent of the Village Council. One Village Council trustee is appointed to the Harbor Commission by the Village Council President. The Harbor Commission reviews all village projects that may affect the streams, lakes, rivers and shoreline within the village and all other waters as may be in the jurisdiction of the village, as they pertain to harbor facilities as established. The Harbor Commission will also make recommendations to the Village Council regarding harbor operations and harbor projects.



## 2.2 Proposal Information

It is the intent of the Harbormaster after receipt of bids to review available funding and proceed with the award process which includes the review and approval by a majority vote of support from the Edward C. Grace Harbor Commission and the Village Council of Elk Rapids.

## 2.3 Requirements

Expectations of Respondents:

1. Barge Length Overall (LOA) maximum of 26 feet
2. Barge beam not to exceed 10 feet
3. Outfitted with minimum of one (1) 125 hp gas outboard engine
4. Internal fuel tank to hold up to a 100-gallon capacity
5. Bottom plating approximately ¼" minimum
6. Covered steering counsel, spud wells, deck fittings, pad eyes (lifting eyes), motor guard, tow post, navigation lights, bow flood light, manhole access, 12V electrical system, USB connection at helm, 120V inverter, vhf radio, hydraulic steering
7. Hydraulic knuckle crane for marine workboat use
8. 1 Trailer to transport barge
9. Capacity full load minimum of 12,000 lbs. (including passengers/gear)







Figure 2: Harbor entrance.

## SECTION 3 – PROPOSAL REQUIREMENTS & GENERAL INFORMATION FOR RESPONDENTS

### 3.1 Submission of Respondent's Proposal

**Receipt of Bids:** Bids shall be submitted in sealed envelopes marked “**Edward C. Grace Memorial Harbor bid for fabrication of work barge**”.

**TO:** Village of Elk Rapids  
Governmental Center  
315 Bridge Street  
Elk Rapids, MI 49629  
**Attn: Harbormaster Mike Singleton**

**DATE: Friday, March 1, 2024**

**TIME: 10:00 a.m., Eastern Standard Time**



All Bids received at such place, date and time will then be publicly opened and read aloud. Bids received after such time will be returned to the respective Bidder, unopened. Bidders submitting Bids will be advised of the results of all the Bid proposals following the award of all contracts.

Mailed bids should be sent to: **Village of Elk Rapids, Attn: Harbormaster, Mike Singleton, 315 Bridge Street, Elk Rapids, MI 49629.**

### **3.2 Examination and Procurement of Documents**

Bidders may obtain complete sets of Bidding Documents from the Village of Elk Rapids after 10:00 a.m. on Friday, March 1, 2024,

Complete and detailed Bidding Documents will be on file, and may be examined by prospective Bidders at:

- A.** Village of Elk Rapids, Governmental Center, 315 Bridge Street, Elk Rapids, MI 49629.
- B.** Builders Exchange of Northwest Michigan, 1373 Barlow, Traverse City, MI 49686

### **3.3 MODIFICATION OR WITHDRAWAL OF BID**

A bid may not be modified, withdrawn, or canceled for a period of one hundred twenty (120) calendar days after the time and date designated for receipt of Bids.

### **3.4 Pre-Bid**

There will be no mandatory pre-bid meeting, however contractors are expected to visit the site and make themselves familiar with existing site conditions. Access to the Edward C. Grace Memorial Harbor and associate facilities may be coordinated with the Harbormaster, Mike Singleton, [Harbormaster@elkrapids.org](mailto:Harbormaster@elkrapids.org) or by calling 231-264-9274.

The Village of Elk Rapids reserves the right to reject any or all proposals for this service and is not limited to the lowest bid.





Figure 3: Sunset over the Pavilion.